

NYTA





NYTA

enjoy light

Wir genießen es, Licht und Leuchten zu gestalten. Die Idee zu jeder Leuchte ist uns dabei besonders wichtig und begleitet uns bis zum fertigen Produkt. Auf dem Weg dorthin klären wir die lichttechnischen Fragen, die Art der Herstellung, definieren die Materialien und Oberflächen, präzisieren die Details und die Handhabung und hinterfragen immer wieder, was dabei notwendig und gut ist und was entfallen kann.

Ist die Idee am Ende dieses Prozesses noch immer klar zu erkennen und zu unserer Zufriedenheit umgesetzt, so haben wir unser Ziel erreicht: Leuchten zu schaffen, die ansprechen, überzeugen und selbstverständlich wirken – Leuchten, an denen unsere Kunden lange ebensolche Freude haben wie wir.

We take great satisfaction and pride in designing light and the sources from which it emanates. It is important to us that our original design ideas are kept alive every step of the way, right down to the finished product. To achieve this we carefully consider all esthetic and technical details and get involved in the manufacturing process. We precisely define materials, surfaces and product details as well as paying meticulous attention to handling and everyday use. We are continuously challenging our designs in order to retain the necessary while weeding out the superfluous. If at the end of this scrupulous process the original design idea is still clearly identifiable and has been translated into a good prototype we have achieved our aim: designing and building lights, lamps, illuminants that – quite literally – please the eye, make an esthetic statement and still blend in matter-of-factly. In short: Light that serves and satisfies our customers as much as it gave us satisfaction in designing it.



DESIGNPREIS
DER
BUNDESREPUBLIK
DEUTSCHLAND
2013
NOMINIERT



German
Design Award
NOMINEE 2014

WINNER OF
FORMLAND
UPGRADED
DESIGN
AWARD
AUTUMN 2013

interior
innovation
award
2014
Winner

DESIGN PLUS
powered by: light+building



Focus Open 2014
Special Mention



German
Design Award
WINNER 2015

Tilt

Die Leuchte mit Haltung
Lighting with poise

Design by jjoo design



Tilt gibt offenes, weiches Licht dorthin, wo es gewünscht ist. Mühelos und intuitiv lässt sich der Schirm mit nur einem Handgriff und ohne Hilfsmittel entlang der langen Öffnung in alle Richtungen schwenken und drehen. Gleich einer Schale, die man um die Lichtquelle bewegt, sammelt er das Licht und lenkt es in den Raum oder auf das zu beleuchtende Objekt.

Der matt lackierte Schirm aus Metall, die Schirmführung aus Edelstahl sowie das Textilkabel machen Tilt zu einer hochwertigen Erscheinung in jeder Umgebung. Eine selbstfixierende Aufhängung sorgt für festen Halt und für eine saubere Ausrichtung in jeder Position.

Tilt emanates an open and soft light, and directs it exactly where it is needed. Easy, intuitive handling allows turning and swiveling the shade along its oblong opening in every direction. It works like a cupped reflector that you can freely move around the light source, thus gathering the light and directing it towards the space or object you want to illuminate.

The matt finish of the metal shade, the guiding peg made from stainless steel as well as the cloth-covered cord make for a high-quality and classy appearance in every conceivable environment. A self-fastening hanging mechanism provides solid purchase and cleanly holds the lamp in position.



Tilt S



Tilt S





Spezifika Specifications

Dreh- und Neigungswinkel
Swivel and tilt angle

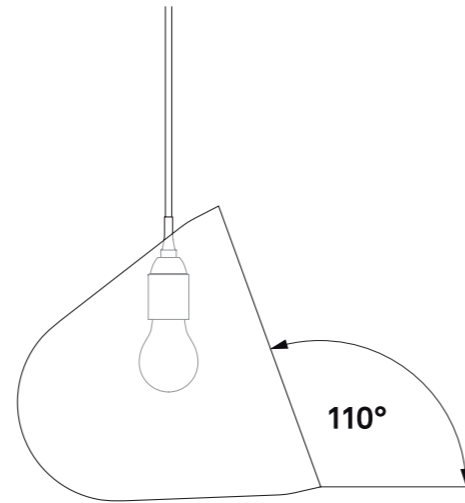
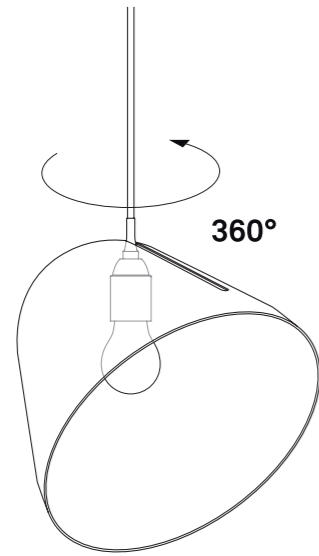

Farben Leuchterschirm & Baldachin
Colours lamp shade & canopy

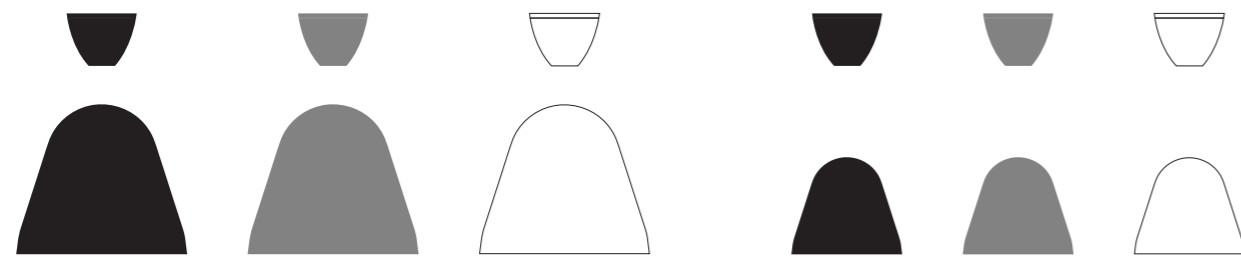

Farben Textilkabel
Colours cloth-covered cord

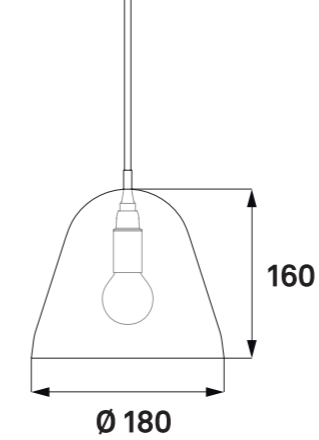
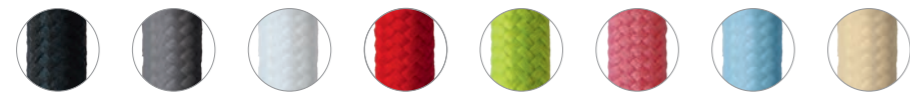

Tilt S

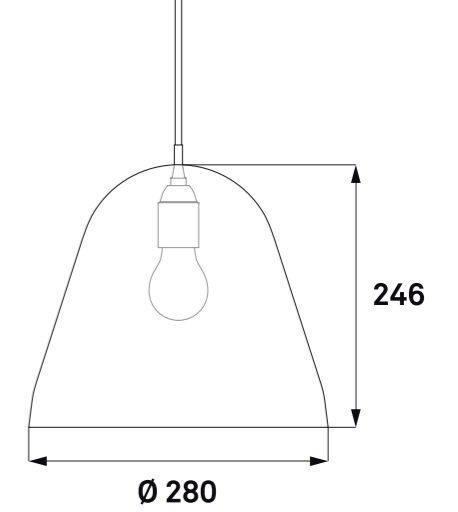

Tilt

Material:	Stahl lackiert, Edelstahl	Aluminium lackiert, Edelstahl
Farbe außen:	schwarz matt, grau matt oder weiß matt	schwarz matt, grau matt oder weiß matt
Farbe innen:	weiß matt	weiß matt
Kabel:	Textilkabel in 8 Farben (schwarz, grau, weiß, rot, hellgrün, altrosa, hellblau, beige)	Textilkabel in 8 Farben (schwarz, grau, weiß, rot, hellgrün, altrosa, hellblau, beige)
Kabellänge:	3 oder 5 Meter	3 oder 5 Meter
Baldachin:	Kunststoff, schwarz, grau oder weiß matt	Kunststoff, schwarz, grau oder weiß matt
Socket:	E 14	E 27
Leuchtmittel:	LED, Halogen, Glühlampe, Kompaktleuchtstoff (max. 46 Watt)	LED, Halogen, Glühlampe, Kompaktleuchtstoff (max. 105 Watt)
Neigungswinkel:	max. 110 Grad	max. 110 Grad
Drehwinkel:	360 Grad	360 Grad
Höhe:	160 Millimeter	246 Millimeter
Durchmesser:	180 Millimeter	280 Millimeter
Gewicht:	900 Gramm	1 Kilogramm
Energieklassen:	Diese Leuchten sind geeignet für Leuchtmittel der Energieklassen A++ bis E	

Materials:	Steel w/ matt finish, stainless steel	Aluminum w/ matt finish, stainless steel
Color outside:	matt black, matt grey or matt white	matt black, matt grey or matt white
Color inside:	matt white	matt white
Cord:	cloth-covered in 8 colour choices (black, grey, white, red, light green, rose, light blue, beige)	cloth-covered in 8 colour choices (black, grey, white, red, light green, rose, light blue, beige)
Length of cord:	3 or 5 meters (ca. 10 or 16,5 ft.)	3 or 5 meters (ca. 10 or 16,5 ft.)
Ceiling canopy:	plastic, matt black, grey or white	plastic, matt black, grey or white
Base:	E 14	E 27
Light source:	LED, Halogen, light bulb, fluorescent lamp (max. 46 Watts)	LED, Halogen, light bulb, fluorescent lamp (max. 105 Watts)
Tilt angle:	max. 110 degrees	max. 110 degrees
Swivel:	360 degrees	360 degrees
Height:	160 millimeters	246 millimeters
Diameter:	180 millimeters	280 millimeters
Weight:	900 grams (ca. 32 ounces)	1 kilogram (ca. 35 ounces)
Energy classes:	These luminaires are compatible with bulbs of the energy classes A++ to E	



NYTA

www.nyta.eu